

APPENDIX AD Residential Docks.

***The Department of Community Affairs hereby adopts Appendix AD 'Residential Docks' as optional.**

SECTION AD101

GENERAL AND SCOPE

AD101.1 General.

This appendix shall be applicable to the minimum standards for the design, construction and maintenance of docks, piers, bulkheads, and waterway structures. The guidelines in this appendix address minimum standards for foundations, design forces, structural integrity, material selection and utilization and construction techniques.

AD101.2 Scope.

The following structures shall be designed in accordance with the requirements of this appendix:

1. Docks, piers, gangways and catwalks, for residential and farm docks and piers shall be constructed by the standards of this appendix or designed by a registered design professional.
2. All bulkheads having an exposed height greater than 5 feet (1525 mm) or with a superimposed load shall be designed by a registered design professional and require special inspection. Special inspection shall be waived for bulkheads of any height constructed from property line to property line of one- and two-family dwellings and including attachment to neighboring bulkheads.

SECTION AD102

DEFINITIONS

AD102.1 General.

The following words and terms shall, for the purposes of this appendix, have the meanings shown herein. Refer to Chapter 2 of this code for general definitions.

BOAT SLIP. A berthing place for one or two watercraft where the watercraft can be securely moored to cleats, piling, or other devices while the boats are in the water. Boat slips are commonly configured as "side-ties" or as single- or double loaded "U" shaped berths.

BULKHEAD. A vertical wall structure designed to retain shoreline material and prevent erosion due to wave activity.

CATWALK. A narrow footway platform extending alongside a structure.

DOCK. A structure extending alongshore or out from the shore into a body of water, usually accommodating multiple boat slips, to which boats may be moored in order to load or unload people or cargo, or to provide access to the water.

GANGWAY. A footway bridge extending from the dock, pier, bulkhead or shore, usually to a floating

structure.

KING PILE. The primary structural member that supports horizontal panels to form a vertical wall sometimes used in bulkhead or groin construction.

PIER. An elevated deck structure, usually pile supported, extending out into the water from the shore.

PILE. A timber, concrete, metal, or composite member embedded into the ground to support or brace a structure.

"Piles" or "piling" are plural forms of "pile."

PRIVATE WATERFRONT STRUCTURES. A dock, pier, bulkhead, or associated structure not open to the general public and with no more than ten total boat slips and no more than ten owners.

PUBLIC WATERFRONT STRUCTURES. A dock, pier, bulkhead, or associated structure located on multi-family residential property (greater than ten dwelling units), public property or commercial property.

SHEET PILE. A pile with a generally slender flat cross section to be embedded into the ground or seabed and meshed or interlocked with like members to form a diaphragm, wall or bulkhead.

SECTION AD103

PERMITS AND APPROVALS

AD103.1 General.

In addition to a building permit, permits may be required from federal, state or county agencies such as the United States Army Corps of Engineers or the Department of Natural Resources. In cases of structures to be built on lakes operated by an electric utility for the generation of power, a permit from the operating utility may also be required.

SECTION AD104

MINIMUM DESIGN LOADS

AD104.1 General.

Every structure shall be of sufficient strength to support the imposed dead, live, snow, wind, impact and seismic loads without exceeding the prescribed stresses for the various materials described elsewhere in this appendix. Adequate consideration shall be made for forces imposed by earth, water, docking and mooring.

AD104.2 Dead Loads.

The weight of the component parts of a structure shall be used in the design when it will influence the strength of the structural elements. All utilities, permanent furniture, dock boxes and mooring hardware should be considered as dead load.

AD104.3 Live Loads.

Design live loads shall be the greatest load that will likely be imposed on the structure, including superimposed loads on retained material that exert horizontal loads on the structure. Minimum live loads are:

1. Fixed piers, docks, catwalks—Private waterfront piers: 40 psf or 300 pounds concentrated load on any 2 foot by 2 foot (610 mm by 610 mm) area. Public waterfront piers: Design loads shall be the greatest combinations of loads exerted on the structure but not less than 60 psf or 300 pounds concentrated load on any 2 foot by 2 foot (610 mm by 610 mm) area.
2. Floating docks—Private waterfront docks: 20 psf, public waterfront docks: 30 psf, or 300 pounds concentrated load on any 2 foot by 2 foot (610 mm by 610 mm) area. Under dead and live load, all floating docks shall have a minimum of 3 inches (76 mm) freeboard from the top of the flotation device, other than low freeboard watercraft (e.g. kayak) launching facilities. Floating docks with roofs shall have a minimum of 3 inches (76 mm) freeboard from the top of the flotation device under a combination of dead, snow and 75 percent of live load. All floating docks subject to this appendix shall have not more than 5 degrees tilt from the horizontal under uniform live loading on one-half of the dock width or under concentrated load of 400 pounds applied within 12 inches (305 mm) of any side.
3. Gangways—Gangways shall be designed for a live load of 100 psf. Flotation for gangway landing shall be designed for 50 psf, live load.
4. Bulkheads, revetments—Design loads shall be the greatest combinations of loads exerted on the structure. Consideration shall be given to horizontal loads exerted by superimposed loads on the retained earth and by inclined surface slopes. Superimposed loads shall be considered when exceeding 50 psf and located within a horizontal distance of three times the height of the bulkhead from the face of the bulkhead.

AD104.4 Snow Loads.

Design snow loads shall be as prescribed in Chapter 3.

AD104.5 Wind Loads.

Design wind loads shall be as prescribed in Chapter 3. In wind regions with a design wind speed greater than 90 mph, the design wind speed with moored vessels shall be no less than 90 mph (3-second gust).

AD104.6 Impact Loads.

Design impact loads shall be as prescribed in Chapter 16 of the International Building Code but not less than 1.25 times the kinetic energy exerted by a striking vessel or vehicle.

AD104.7 Seismic Loads.

Design seismic loads shall be as prescribed in Chapter 3. Seismic loads are not applicable for any structure exempted from design by a registered design professional.

AD104.8 Water Loads.

Hydrostatic and hydrodynamic loadings shall be considered as follows:

AD104.8.1 Hydrostatic Pressures.

Hydrostatic pressures shall be considered in conjunction with the equivalent fluid pressure of soil and any surcharge acting on the structure. For bulkheads hydrostatic pressures shall be estimated based on maximum difference between retained and offshore water surface elevations.

AD104.8.2 Current Loads.

Current loads for structures and vessels shall be determined from records on current velocity using accepted engineering practice.

AD104.8.3 Forces Due to Passing Vessels.

All piers, floating docks, bulkheads and revetments shall be designed for water loading generated by wind and passing vessels.

AD104.9 Erosion.

The effects of reasonably predictable erosion, propeller wash-induced scour, and wave-induced scour shall be given ample consideration.

AD104.10 Water Levels.

The ability to accommodate dead, live, wind, current and wave loadings for the range of water levels (from low water to base flood level) anticipated at the site shall be given ample consideration. For public and private floating docks, guide piling systems shall be capable of accommodating water levels extending a minimum of 2 feet (610 mm) above base flood elevation plus the freeboard of the dock structure.

SECTION AD105

Materials

AD105.1 General.

The quality of materials and fasteners used for load-supporting purposes shall conform to accepted engineering practice.

AD105.2 Piling and Foundations.

Materials used for piling and repairing piling shall comply with applicable provisions of Sections AD105.3 through AD105.7.

AD105.2.1 Helical Anchors.

Helical anchors shall be hot-dipped galvanized or stainless steel. A representative number of helical anchors subjected to tensile loading shall be load tested in accordance with ASTM D3689 to two times their design load capacity. Load testing of anchors in tension shall include creep testing of a representative number of the anchors. Helical anchors shall be designed and installed as determined by a registered design professional.

AD105.3 Wood.

Wood shall be pressure treated with a preservative recommended by the American Wood Preservers' Association for the specific application. Wood species, preservative treatment, minimum lumber size, and lumber grade shall be in accordance with Table AD105.3. Handrails, guardrails, wallcaps, and decking may be constructed of naturally durable species where located above the normal high water mark.

Table AD105.3

SPECIFICATIONS FOR SOUTHERN PINE^b LUMBER IN FRESH AND SALT WATER SERVICE

LOCATION	COMPONENT	AWPA USE CATEGORY ^{a,d}		DIMENSIONS (inches)	LUMBER GRADE		MOISTURE CONTENT AT TREATMENT
		Saltwater	Freshwater		Saltwater	Freshwater	
Above Normal High Water	Decking ^c	3B	3B	5/4 2 Nominal Min.	Premium No. 2	Premium No. 2	Surfaced Dry 19%
	Guardrails	3B	3B	2 Nominal Min.	No. 2	No. 2	Surfaced Dry 19%
	Wallcaps	3B	3B	2 Nominal Min.	No. 2	No. 2	Surfaced Dry 19%
	Walers	3B	3B	4 × 6 Nominal	No. 2	No. 2	Surfaced Dry 19%
	Cross Bracing	3B	3B	2 to 4 Nominal	No. 2	No. 2	Surfaced Dry 19%
Splash Zone	Split Pile Caps	4B	4B	2 to 4 Nominal	No. 2	No. 2	Surfaced Dry 19%
	Stringers	4B	4B	2 Nominal	No. 2	No. 2	Surfaced Dry 19%
Below Normal High Water	Sheet Piles	5B	4C	2 to 4 Nominal	Marine No. 1 ^e	No. 2	Surfaced Dry 19%
	Walers	5B	4C	4 × 6 Nominal	Marine No. 1 ^e	No. 2	KD 20% or less or Dry 23%

	Cross Bracing	5B	4C	2 to 4 Nominal	Marine No. 1 ^g	No. 2	Surfaced Dry 19%
	Rectangular Timber Piles	Not Allowed ^f	4C	6 × 6 Nominal	Not Allowed ^f	No. 2	KD 20% or less or Dry 23%
	Round Timber Piles	5B ^f	4C	ASTM D25	ASTM D25	ASTM D25	KD 25% or Less
Engineered Lumber	Glulam Timber	5B	4B	4 Nominal Min.	Note e	Note e	12% Average
	Parallel Strand Lumber	5B	4B	3 1/2 Minimum	1.8E or Better	1.8E or Better	per manufacturer's specifications

- a. Lumber shall be pressure treated with preservative treatment in accordance with AWPA U1.
- b. At the discretion of the building official, lumber species other than Southern Pine may be approved when span tables for wet use conditions are submitted, and the lumber is treated for comparable service life to the treatment specifications required by Table AD 105.3.
- c. Wood composite decking, treated or untreated, shall provide equivalent service life to the treated decking specified in Table AD 105.3
- d. All notches, holes, and field cuts shall be field treated in accordance with AWPA M4.
- e. Glulam grade shall be specified as a layup combination or stress class in accordance with the National Design Specification or the manufacturer's published data. Layup combinations shall consist of species and grades capable of the treatment retentions equivalent to the AWPA use categories specified in Table AD 105.3
- f. Commercial pile wraps may be used to extend the life expectancy of timber piles exposed to marine borers.
- g. AWPA requirements for Marine No. 1 specify that no heartwood be exposed on any face prior to preservative treatment.

AD105.3.1 Wood Connections.

All steel bolts, rods and other hardware shall be hot-dipped galvanized or protected with an equivalent system. All bolts, rods and other metal materials shall be no smaller than 5/8-inch in diameter. Beams, girders or pile caps shall be attached to the piling with a minimum of two 5/8-inch hot-dip galvanized steel bolts per beam member through bolted at each piling connection. Piling shall not be notched so that the cross-section is reduced below 50 percent. Threaded fasteners shall not be tightened directly against wood surfaces but used only in conjunction with standard ogee or flat washers. Cold formed metal connectors shall not be used in wet applications or applications subject to wetting and drying cycles. Mooring hardware, including cleats, and pile guides shall be through bolted using sizes recommended by the manufacturer.

AD105.4 Aluminum.

Aluminum bulkhead sheets or aluminum bulkhead or dock components shall be of proper alloy to resist corrosive elements in the adjacent water and soil. Bulkhead components and hardware shall be aluminum or stainless steel. Aluminum shall be galvanically and physically isolated from concrete and galvanically isolated from steel. Connection hardware and fasteners for aluminum components may be stainless steel or galvanized steel if isolated from aluminum structural elements.

AD105.5 Plastics and Composites.

Bulkheads, structural shapes, plates, and guardrail systems manufactured from vinyl chloride based materials or fiber reinforced polymer (FRP) materials shall be designed to comply with manufacturer's published load tables or manufacturer's published mechanical properties. Plastic and composite members shall contain additives to inhibit ultra violet radiation degradation or shall be protected from ultra violet radiation by an appropriate coating.

AD105.6 Masonry.

Masonry used in bulkheads and dock work shall comply with Chapter 21 of the International Building Code.

SECTION AD106

CONSTRUCTION OF PIERS, DOCKS, CATWALKS, GANGWAYS, AND FLOATING DOCKS.

AD106.1 Fixed Piers.

Fixed piers shall be constructed in accordance with Sections AD106.1.1 through AD106.1.4.

AD106.1.1 Required Depth of Piles.

Fixed piers shall be supported by pilings with tip penetrations dependent on the soil conditions and the total applied load. Pier support by shallow piling, legs or columns with point bearing on rock shall have provisions to resist horizontal forces and overturning, as well as flotation uplift. Piles shall be installed in accordance with the requirements of this section. (See figure AD106.1.1.1)

Figure AD106.1.1.1 Pile Depth.

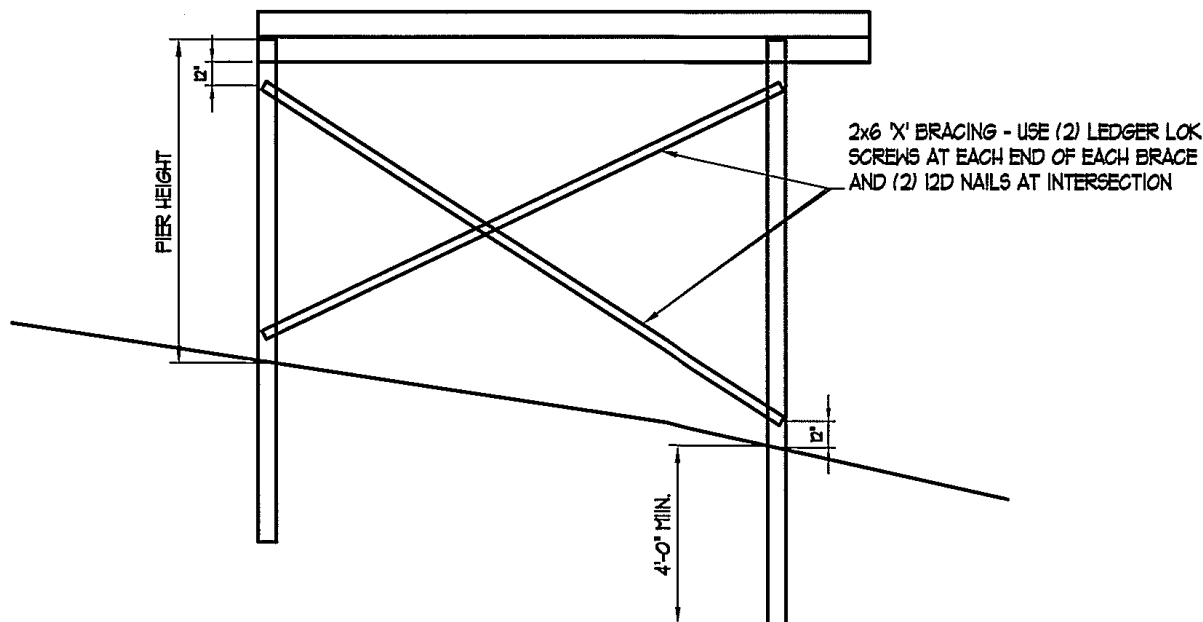

PIER LENGTH CHART		
HEIGHT	PIER SIZE (INCHES)	REMARKS
8'-0 TO 14'-0	5" DIA.	0.46 PCF CCA
14'-0 TO 20'-0	6" DIA.	0.46 PCF CCA

- Provide a minimum of two braces in opposing direction for each section of dock.
- Piers are to be #2 grade lumber treated pine with a minimum preservative level of 0.40 PCF CCA. Piers to be continuous not splice from soil to deck. Verify 4'-0" min penetration.

AD106.1.2 Structural Steel and Concrete Members.

Structural steel members shall be designed in accordance with AISC 360. Concrete members shall be designed in accordance with ACI 318, and the materials requirements of this appendix.

AD106.1.3 Size of Wood Piles.

Piles shall be sized in accordance with the American Wood Council National Design Specification. In no case shall round timber piles be less than 5 - 7 inches (178 mm) in diameter at the butt and have a minimum tip diameter of less than 5 1/2 inches (138 mm). Rectangular timber piles shall not be less than nominal 6 inches by 6 inches (152 mm by 152 mm). (See figure AD106.1.1.1)

AD106.1.4 Bracing of Wood Piles.

Where required by design, bracing shall be sized to limit stresses in the piles from lateral loads in accordance with the American Wood Council National Design Specification to prevent buckling. (See figure AD106.1.1.1)

AD106.1.5 Wood Girder and Joist Spans.

Maximum spans for pier pile caps or girders and joists or stringers shall be determined in accordance with the American Wood Council National Design Specification considering the member to be subject to wet use and Table AD106.1.5.1 Maximum Joist Span Length.

AD106.1.5.1 MAXIMUM JOIST SPAN LENGTH.

TABLE 1: MAXIMUM JOIST SPAN LENGTH¹

Joists without Overhangs				Joists with Overhangs			
Joist Spacing → Joist Size ↓	12"	16"	24"	Joist Spacing → Joist Size ↓	12"	16"	24"
2x8	13'- 1"	11'- 10"	9'- 8"	2x8	10'- 1"	10'- 1"	9'- 8"
2x10	16'- 2"	14'- 0"	11'- 5"	2x10	14'- 6"	14'- 0"	11'- 5"
2x12	18'- 0"	16'- 6"	13'- 6"	2x12	18'- 0"	16'- 6"	13'- 6"

1. Spans are based on 40 PSF live load, 10 PSF dead load, southern pine #2, nominal loading duration, wet service conditions and deflections of $\Delta = \ell/360$ for main span and $\ell/180$ for overhang with a 220-pound point load.
2. Joist must meet the requirements of this appendix and must be spaced a maximum of 24" on center for 2x6 decking and a maximum of 16" on center for composite deck material and 4/5" decking.

AD106.1.6 Connections.

Connections between piling or legs to pile caps, stringers, beams, bracing and deck shall have sufficient capacity to safely support all applied loads and provide transfer of load to adjoining members. All hardware shall be hot dipped galvanized or G60 plated. This included bolts, washers, nuts, pins and screws.

AD106.1.7 Gangways.

On lakes and other inland waters, the maximum slope shall be 3:1 not less than 90 percent of the time and 2 1/2:1 not more than 10 percent of the time.

AD106.2 Flotation Units.

Flotation units shall be foam-filled encapsulated floats or polystyrene billets securely wrapped with Class I woven geotextile fabric in accordance with AASHTO M288. The use of metal barrels not specifically designed for use as flotation devices and unwrapped polystyrene billets are prohibited.

AD106.3 Electrical Service.

All electrical service to marine structures shall be in accordance with the National Electrical Code.

AD106.4 Fire Protection.

All fire protection for marine structures shall be in accordance with applicable provisions of the International Fire Code.

AD106.6 Guardrails.

For walkways, access piers, steps or ramps, guardrails or other safety provisions shall be provided along the edges where the vertical drop to the lesser of the mean low water level, normal low water level (sounds), normal pool (lakes and rivers) or mud line exceeds 6 feet (1828.8 mm). Edges having a primary function other than walks or access ways, such as docking frontage and swimming access shall not require guardrails. Guardrails shall be a minimum of 42 inches (1047 mm) high and shall prevent the passage of a 21-inch (533 mm) sphere. Edge protection shall be provided as required by other rules.

Exception: For private waterfront piers and docks, guardrails or other safety provisions shall be provided along the edges where the vertical drop to the lesser of the mean low water level, normal low water level (sounds), normal pool (lakes and rivers) or mud line exceeds 8 feet (2438 mm). Guardrails shall be a minimum of 36 inches (914 mm) high and shall prevent the passage of a 21-inch (533 mm) sphere. Edge protection shall be provided as required by other rules.

AD106.7 Accessibility.

Piers, docks, catwalks, gangways, and floating docks shall comply with ADA requirements and ANSI/ICC A117.1 for accessibility.

AD106.8 Egress.

Piers and docks shall be provided with means of egress in accordance with Sections AD106.8.1 through AD106.8.4.

AD106.8.1 Occupant Load.

Occupant load for piers and docks shall be calculated as follows:

AD106.8.1.1 Piers and Boardwalks.

Occupant load for piers and boardwalks intended for recreational fishing shall be calculated based on 3 linear feet (914 linear mm) of rail per person on the perimeter plus 50 square feet (4.65 m²) per person on a net area with a perimeter 3 feet (914 mm) inside the rail. Occupant load for piers and boardwalks intended for other uses shall be in accordance with Chapter 10 of the International Building Code.

AD106.8.1.2 Private Waterfront Docks.

Occupant load for private waterfront docks shall be calculated based on 20 square feet (1.86 m²) per person.

AD106.8.2 Piers.

Piers intended for recreational fishing, assembly, or educational purposes with travel distance to exit discharge exceeding 600 feet (183 m) and greater than 15 feet (4572 mm) above mean low water shall have emergency access ladders at 300 feet (91.4 m) intervals and at the end of the pier. The pier shall be constructed of noncombustible material with the exception that the floor decking may be heavy timber.

AD106.8.3 Public Waterfront Docks.

Public waterfront docks intended for mooring of private pleasure craft with travel distance to exit discharge in excess of 600 feet (183 m) shall have a second means of egress or a means of rescue from the water. Construction for these docks shall be noncombustible with the exception that wood walers may be embedded in the dock edges for attachment of mooring hardware.

AD106.8.4 Buildings Constructed on Piers and Docks.

Buildings constructed on public waterfront piers and docks shall comply with the requirements of all applicable provisions of the International Building Code.

SECTION AD107

CONSTRUCTION: BULKHEADS AND REVETMENTS.

AD107.1 Bulkheads.

Bulkheads shall be constructed in accordance with Sections AD107.1.1 through AD107.1.5.

AD107.1.1 General.

Bulkheads shall be constructed in a manner to be effective against erosion and provide for bank stabilization. The bulkhead system may consist of any of the following or combinations thereof: braced sheet pile walls with tie backs, king piles and horizontal panels, gravity walls, cantilever and counterfort retaining walls. Bulkhead walls shall be constructed to prevent passage of fine material (see ASTM D2487) through joints or cracks from the fill side to the stream side.

AD107.1.2 Systems.

Local site conditions and performance of bulkheads in service shall govern in selection of a system. The potential for erosion and scour at the mud line shall also be investigated, and compensating features shall be reflected in the construction. Bulkheads shall be terminated by either tying into adjoining structures or by extending the bulkhead line a minimum of 10 feet (3050 mm) in a landward direction at an angle of not less than 45 degrees to the shoreline in order to protect against end erosion or flanking by wave action. No structure shall be terminated without regard for end anchorage and stabilization.

AD107.1.3 Guardrails.

Where designated public walkways, steps or ramps run adjacent to bulkheads within 6 feet (1829 mm), guardrails or other safety provisions shall be provided along the top of the wall where the vertical drop to the lesser of the mean low water level, normal low water level (sounds), normal pool (lakes and rivers) or mud line exceeds 6 feet (1829 mm). Guardrails shall be designed in accordance with Chapter 16 for balcony guardrails. Guardrails shall be 42 inches (1067 mm) high and shall prevent the passage of a 21-inch (533 mm) sphere except where required otherwise by Chapter 11. Edge protection shall be provided as required by other rules.

Exception: For private waterfront bulkheads with designated walkways within 6 feet (1829 mm), guardrails or other safety provisions shall be provided along the edges where the vertical drop to the lesser of the mean low water level, normal low water level (sounds), normal pool (lakes and rivers) or mud line exceeds 8 feet (2438 mm). Guardrails shall be a minimum of 36 inches (914 mm) high and shall prevent the passage of a 21-inch (533 mm) sphere. A wall cap 30 inches (762 mm) or less in width shall not be considered a designated walkway unless it is connected to a walkway. Edge protection shall be provided as required by other rules.

AD107.1.4 Wood Construction.

For wood grades, member sizes, preservative treatment, and protection of metal fasteners and fittings see Section AD105.3.

AD107.1.5 Bulkheads of Materials Other Than Wood.

Vinyl, fiber reinforced polymer, aluminum, concrete and steel bulkheads shall be constructed in a manner to ensure performance. Connections shall be designed to resist the full applied load. For materials and corrosion protection, reference Sections AD105.4 through AD105.7.

AD107.2 Revetments.

Revetments shall be constructed in accordance with Sections AD107.2.1 through AD107.2.2

AD107.2.1 Rigid Revetments.

Rigid revetments shall be founded on a firm foundation to prevent undermining and progressive instability. Provisions shall be made to provide for adequate toe protection to compensate for known or anticipated scour. Additional protection may be needed in active areas and may consist of sheet piling along the toe or stone rip rap. An adequate pattern of weep holes shall be provided in the face to relieve hydrostatic pressure behind the wall. Joints shall be sealed or provided with a properly designed filter to prevent loss of fines from the protected slope.

AD107.2.2 Flexible Revetments.

Adequate provisions shall be made to prevent migration of fine materials through the structure. The face shall not be steeper than one unit horizontal to one unit vertical. Flatter slopes may be needed for stability depending on the construction materials and site conditions. The face may consist of armor stone, rip rap, or individual interlocking concrete units or poured concrete. Toe

protection provisions shall be provided as discussed for the rigid type and the top of slope shall be detailed to prevent erosions under the revetment from surface water runoff. Flexible revetments shall be provided with a filter layer designed to prevent loss of fines from the protected slope and to relieve hydrostatic pressure behind the face.